

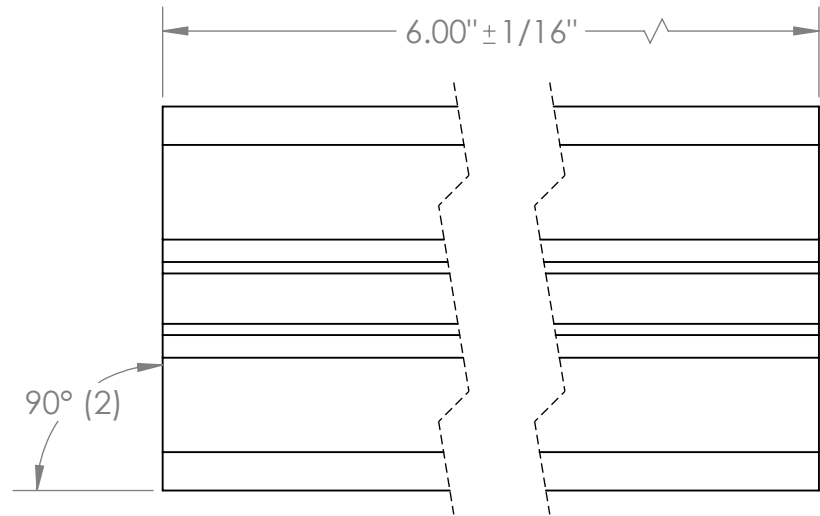

REVISION HISTORY			
REV.	DESCRIPTION	DATE	DRAWN BY
1	ORIGINAL PRINT	12/10/2025	E. SCIME

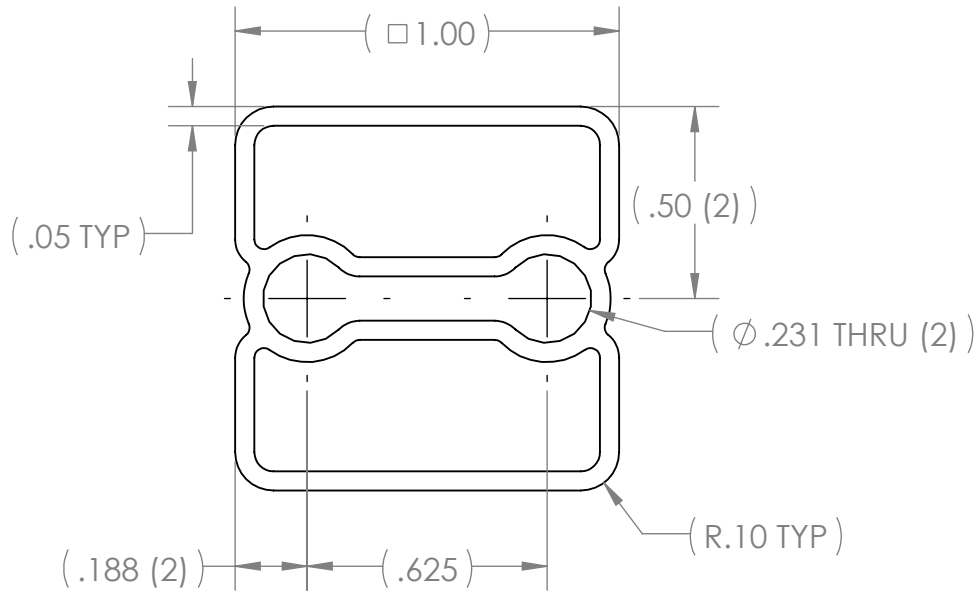

\*\*\* SEE CAD FOR ADDITIONAL TOOLPATH INFO\*\*\*

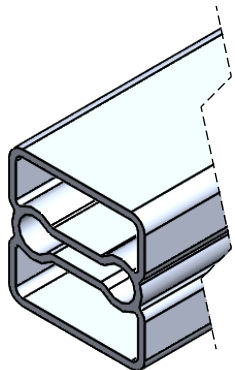

UNLESS OTHERWISE SPECIFIED:		COMMENTS:					
<b>DIMENSIONS ARE IN INCHES</b>		DUAL DIMENSIONS ARE IN MILLIMETERS.		TITLE:			
TOLERANCES: FRACTIONAL $\pm 1/16$ ANGULAR: MACH $\pm 1^\circ$ ANGULAR: BEND $\pm 5^\circ$ ONE PLACE DECIMAL $\pm 0.1$ TWO PLACE DECIMAL $\pm 0.01$ THREE PLACE DECIMAL $\pm 0.005$ FOUR PLACE DECIMAL $\pm 0.0005$		BREAK ALL SHARP EDGES.		6IN PEANUT			
MATERIAL ex-3090 6063-T6 AL		CHECKED	NAME PY	DATE 12/10/25	SIZE <b>A</b>	DWG. NO. am-3090-0600	REV 1
FINISH DEBURRED		MFG APPR.		SCALE: 2:1		SHEET 1 OF 1	
DO NOT SCALE DRAWING		Q.A.					